



Freilauf  
Overrunning clutch  
Roue Libre

F5/1R-2300-1 3/8" (6)

Bestell-Nr.  
Part No.  
Réf. No. **115934**

Zeichnungs-Nr.  
Drawing No.  
Réf. du plan **56.247.40**

Datum  
Date **21.04.2006**

Seite  
Page **1** von  
of **1**  
de **1**

Für Kunde  
for customer  
pour client

**Claas Saulgau**

Kundenzeichnungs-Nr.  
Customer drawing No.  
Réf. du plan client **0935 965.0**

Maschinenart  
Machine  
Machine

Type  
Type  
Type

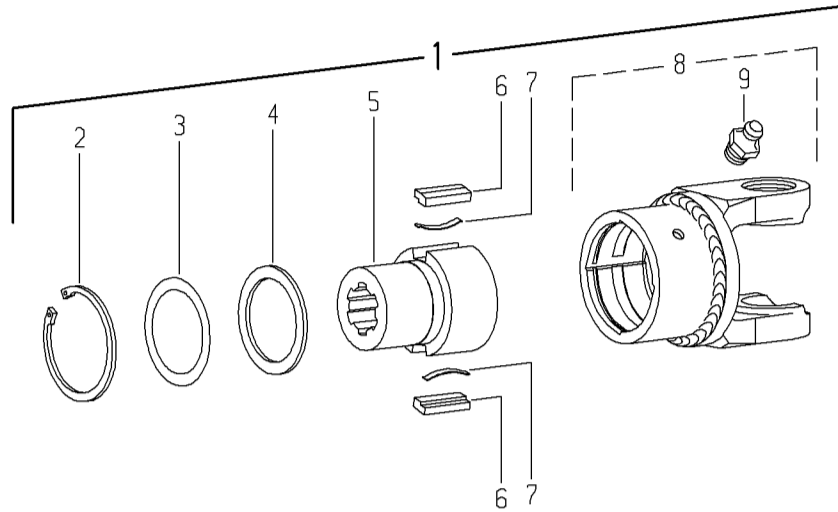

Pos.-Nr. Item Repère	GKN Walterscheid Bestell-Nr. Part No. Réf. No.	Zeichnungs-Nr. Drawing No. Réf. du Plan	Claas Bestell-Nr. Part No. Réf. No.	Stückzahl Quantity Quantité	Technische Angaben Technical data Données techniques	Benennung	Description	Désignation
1	115934	56.247.40	0935 965.0	1	F5/1R-2300-1 3/8" (6)	Sperrkeilfreilauf; Rechtsdreh Sinn	Key-type overrunning clutch; right-hand rotation	Roue libre à roquets; rotation à droite
2	702100	62.14.01	?	1	72x2,5	Sicherungsring	Retaining ring	Jonc
3	116141	agraset 150	0138 562.0	1		Paßscheiben-Satz	Shim kit	Jeu de rondelles de calage
4	304235	16.20.67	?	1	DIN988-S56x72	Stützscheibe	Supporting ring	Rondelle pour bague de frein
5	115933	56.19.233	0933 009.0	1	F5/1-1 3/8" (6)	Nabe	Hub	Moyeu
6	348133	16.50.35	0814 228.0	2	13x7x37,8	Sperrkeil	Key	Rochet
7	348132	66.19.01	0814 229.0	2	0,4x5x36	Blattfeder	Leaf spring	Ressort-Lame
8	365415	21.31.56	0822 377.0	1	F5/1R-2300	Kupplungsgehäuse komplett; Rechtsdreh Sinn	Clutch housing complete; right-hand rotation	Boîtier complet; rotation à droite
9	020672	63.12.01	0179 838.0	1	DIN71412-AM8x1	Kegel-Schmiernippel	Lubrication fitting	Graisser
	304291	agraset 116		1	50 g	Spezialfett	Special grease	Lubrifiant spécial