

**MONTAGE- UND BETRIEBSANLEITUNG
INSTALLATION AND OPERATING INSTRUCTIONS
INSTRUCTIONS DE MONTAGE ET D'UTILISATION**

29.11.2021

**MECHANISCHE FERNBEDIENUNG FB 2000
NACHRÜSTSATZ**

**MECHANICAL REMOTE CONTROL FB 2000
RETROFIT KIT**

**TÉLÉCOMMANDE MÉCANIQUE FB 2000
KIT D'ADAPTATION**

WICHTIGE HINWEISE:

siehe separates Dokument BA_TASC_400002, www.walterscheid.com/downloads/

IMPORTANT NOTES:

see separate document BA_TASC_400002, www.walterscheid.com/downloads/

NOTES IMPORTANTES:

voir document séparé BA_TASC_400002, www.walterscheid.com/downloads/

MECHANICAL REMOTE CONTROL FB 2000

1. DESCRIPTION:

The mechanical remote control makes disconnecting of vehicles more convenient. The retrofit kit FB 2000 is suitable for automatic couplings of the 2000 and 2000X series. It mainly consists of a Bowden cable, Bowden cable lever and a hook for the coupling shaft. After installation, the automatic coupling can be opened by acting the Bowden cable lever from the cabin.



IMPORTANT:

To avoid injury, protective gloves, safety glasses and safety shoes must be worn during all dismantling/ assembly actions described in this chapter.

Environment:

Lubricants can enter the environment. Environmental pollution: Collect, store and correctly dispose of lubricants in suitable containers.

2. INSTALLATION AND OPERATION:



WARNING:

Throughout installation, the coupling must remain in the locked position. The installation and the laying of the bowden cable must guarantee, that unintended opening of the coupling is excluded.

2.1 INSTALLATION OF RETROFIT KIT FB 2000:

(see figure 1)

Push the pull lever spring (1) with the U-shaped leg onto the pull lever (2) and engage the leg in the pull lever. Insert the pull lever with the pull lever spring on the side of the hand lever facing away from the handle and insert the long spring leg into the 4 mm hole in the coupling housing (6). Secure the pull lever by driving in the 8x36 (3) dowel pin on the hand lever. The dowel pin should protrude from the hole in the hand lever at the same ends. Fasten the FB 2000 bracket (4) to the coupling housing using the two 8x20 notches (5) so that the mounting hole in the holder points outwards and towards the pull lever, as shown in figure 1.

2.2 INSTALLATION AND OPERATION OF BOWDEN CABLE:

(See figure 1 and 2)

Using a suitable Bowden cable with lever (e.g. Meflex or SFK), the coupling can be opened from the cabin. For this purpose, the end of the Bowden cable is hooked into the hook of the pull lever (2) and then countered in the mounting hole of the bracket (4). Usually the preload on the bowden cables can be adjusted using two nuts. The lever is attached to a suitable position in the cabin in accordance with the manufacturer's installation and operating instructions. After each opening, the lever must be pushed in his start position.

2.3 CONTROL OF INSTALLATION:

Open the coupling by means of the lever. The coupling pin must be locked in the upper position. Is this not the case, the Bowden cable does not make enough travel. Therefore the bowden cable must be adjusted new. See also instructions of the bowden cable supplier.



WARNING:

Correct locking of the coupling is only ensured if the laterally projecting safety pins disappear completely in the housing of the coupling mechanism, see also installation and

operating instructions of the series 2000. Only then has the coupling pin moved completely into the saddle sleeve and is a secure connection guaranteed. This must be checked after every coupling procedure.

3. MAINTENANCE:

The parts manufactured by Walterscheid (retrofit kit FB 2000) are products that do not require maintenance. The maintenance of the bowden cable can be found in the information from the respective manufacturer.

3.1 CARE:

The coupling and thus also the remote control unit must always be cleared of dirt and corrosion in order to ensure perfect functioning.

3.2 CLEANING AND LUBRICATION:

- > All moving parts must be lubricated regularly (depending on the period of use) and checked for ease of movement.
- > Avoid cleaning with high pressure cleaners if possible. If this does happen, the parts must be re-lubricated.



IMPORTANT:

When replacing components make sure that only original Walterscheid spares are used. If the vehicle owner does not have the appropriate skilled workers and the necessary technical equipment, the replacement may only be performed by a specialist workshop.



WARNING:

SAFETY NOTES:

- > The user is obliged to always operate the coupling and the remote control unit in perfect condition and to forbid its use by unauthorised persons.
- > Unauthorised conversion or modification of the coupling and the remote control unit is not permitted.

Bild 1: Nachrüstset FB 2000

Figure 1: Retrofit kit FB 2000

Figure 1: Kit d'adaptation FB 2000

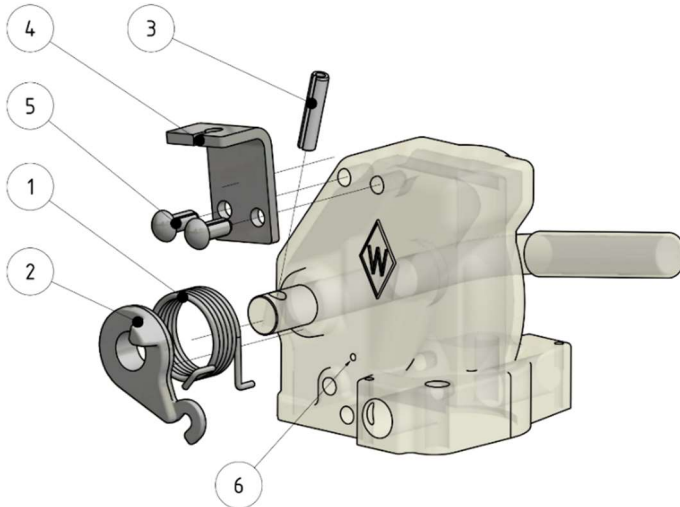

Legende:

- 1.....Zughebelfeder
- 2.....Zughebel
- 3.....Spannstift 8x36
- 4.....Halter FB 2000
- 5.....Kerbnägel 8x20
- 6.....Bohrung am Kupplungsgehäuse

Legend:

- 1..... lever spring
- 2..... pull lever
- 3..... dowel pin 8x36
- 4..... bracket FB 2000
- 5..... notches 8x20
- 6..... hole in the coupling housing

Légende:

- 1 ressort du levier
- 2 levier de tension
- 3 goupille 8x36
- 4 support FB 2000
- 5 clous cannelés 8x20
- 6 trou sur le carter d'embrayage

Bild 2: Bowdenzug mit Hebel

Figure 2: Bowden cable with lever

Figure 2: Câble Bowden avec levier

