

**MONTAGE- UND BETRIEBSANLEITUNG
INSTALLATION AND OPERATING INSTRUCTIONS
INSTRUCTIONS DE MONTAGE ET D'UTILISATION**

09.05.2022

KUPPLUNGSKUGEL 80
BESCHREIBUNG, BEDIENUNG, WARTUNG

COUPLING BALL 80
DESCRIPTION, OPERATION, MAINTENANCE

BOULE D'ATTELAGE 80
DESCRIPTION, UTILISATION, MAINTENANCE

WICHTIGE HINWEISE:

siehe separates Dokument BA_TASC_400002, www.walterscheid.com/downloads/

IMPORTATANT NOTES:

see separate document BA_TASC_400002, www.walterscheid.com/downloads/

NOTES IMPORTANTES:

voir document séparé BA_TASC_400002, www.walterscheid.com/downloads/

COUPLING BALL 80

Ball couplings 80 can be supplied as flange coupling, height-adjustable slider, ball drawbar or towing frame with ball. See also appropriate assembly and operating instructions as well as examples in figure 1.

OPERATING RANGE:

For use on agricultural or forestry vehicles, self-propelled work machines or trailers.

1. DESCRIPTION:

The ball coupling dimensions and field of application complying with ISO 24347, VO (EU) 2015/208 and regulation UN ECE R147, class a80.

In its normal state, the device is in coupled and locked position.

Only for connection with coupling heads 80 (ball-type trailer shank) according to ISO 24347 or UN ECE R147, class b80.

PIVOT ANGLE:

The following pivot angles can be achieved with the coupling ball 80 and the above couplings heads 80 (not simultaneously) can be achieved, disregarding restrictions caused by a towing bracket or other components in which the ball is installed:

(see Figure 4: three-dimensional reference system according to ISO 4130)

- > Angle around the X axis = longitudinal axis: 35°
- > Angle around the Y axis = transverse axis: 35° (see Figure 5)
- > Angle around the Z axis = vertical axis: 90°



IMPORTANT:

To avoid injury, protective gloves, safety glasses and safety shoes must be worn during all dismantling/ assembly actions described in this chapter.

Environment:

Lubricants can enter the environment. Environmental pollution: Collect, store and correctly dispose of lubricants in suitable containers.

2. OPERATION:

(see Figure 2)



WARNING:

The pertinent safety regulations must be observed when coupling and uncoupling. No one may stand between the vehicles. The ball coupling may only be operated in locked condition.

When coupling and uncoupling, the drawbar must be as horizontal as possible relative to the coupling.

2.1 COUPLING:

- > Remove the lynch pin (6) of the top retainer pin (5) and pull out the pin.
- > Pivot the retainer (2) through 90° into the lateral position.
- > Move the ball-type trailer shank over the ball (1).
- > Lower the drawbar by means of the drawbar support or a similar device.

- > Pivot the retainer (2) back into the direction of travel so that it is above the coupling head (ball-type trailer shank).
- > Secure with the retainer pin (5) and the linch pin (6). Check the correct fit of the linch pin.

2.2 UNCOUPLING:

- > Use supporting jacks or similar to stop the trailer rolling away.
- > Remove the linch pin (6) of the retainer pin (5) and pull out the retainer pin.
- > Pivot the retainer (2) through 90° into the lateral position.
- > Raise the drawbar by means of the drawbar support.
- > Move the tractor forwards.
- > Pivot the retainer (2) into the direction of travel and secure it with the retainer pin (5) and the linch pin (6). Check the correct fit of the linch pin.

2.3 ADJUSTABLE RETAINER:

(see Figure 3)

The adjustable retainer serves to compensate for wear on the ball-type trailer shank and/or the retainer. The maximum adjustment path is 10 mm, and the retainer is set at the factory in such a way that it can be adjusted 3 mm in the upward direction and 7 mm in the downward direction.

- > Remove the retainer pin (4+5).
- > Pull the retainer (2) out of the hole in the ball-type coupling (7).
- > By turning the set screw (8), which is screwed into the bottom of the retainer, the height of the retainer can be adjusted.
- > Replace the retainer in the ball carrier.
- > Swing the retainer (2) into the direction of travel and secure it with the retainer pins (4+5) and the linch pins (6). Check the correct fit of the linch pins.



IMPORTANT:

Setting the retainer too tightly can damage the ball-type coupling, the ball-type trailer shank and the equipment to be connected. Always ensure that the retainer has min. 0.5 mm, max. 1 mm clearance relative to the surface of the ball-type trailer shank.

3. MAINTENANCE:

(see Figure 1)

3.1 CARE:

- > The coupling ball must be lubricated at regular intervals, especially after cleaning with a pressure washer. If a lubrication fitting is on the ball-type trailer shank, the ball can be supplied with grease via the central lubrication.
- > The retainer (2) should be pulled out completely at regular intervals, depending on the frequency of use, and any dirt in the bearing has to be eliminated. Both retainer pins must be removed beforehand for this purpose. Subsequently re-grease the bearing.
- > The coupling must be lubricated with water-resistant, multi-purpose grease (Grease type: lithium saponified, consistency class: NL-GI2).

3.2 CHECKS:

- > Coupling ball (1):
The ball diameter must not be smaller than 78.5 mm at any point in the diameter. If the dimension is below the limit, the ball must be replaced or, if this has already happened twice, the coupling ball

must be replaced. A separately available Walterscheid test gauge can be used to comfortably control the wear limit.

> Retainer (2):

There is a wear mark on the retainer. If the marking can no longer be fully recognized, the permissible wear is reached and the retainer must be replaced. When replacing the retainer, the compression and torsion spring of the adjusting screw must always be replaced.

> Height play:

If the height play of the coupling ball exceeds 5 mm in closed state, the appropriate parts such as retainer, ball or coupling head (ball-type trailer shank) must be replaced.

3.3 REPLACING THE BALL:

The ball (1) can be replaced twice at most. Replacement is necessary when the ball diameter has become less than 78.5 mm at any point. Wear limits can be checked conveniently by means of a separately available Walterscheid test gauge. A tool for the locknut is also available. The replacement of the ball 80 may only be carried out by authorised and certified specialist workshops. For more information on ball replacement, visit www.walterscheid.com.



IMPORTANT:

Use only original Walterscheid spares when replacing parts. If the vehicle owner does not have the appropriate skilled workers and the necessary technical equipment, the replacement may only be performed by a specialist workshop.



WARNING:

SAFETY NOTES:

- > The user is obliged to always operate the coupling in perfect condition and to forbid its use by unauthorised persons.
- > The loads indicated on the type plate may not be exceeded.
- > Unauthorised conversion or modification of the coupling is not permitted.

Bild 1 – Beispiele von Baugruppen mit Kupplungskugel 80
Figure 1 – Examples of assemblies with coupling ball 80
Figure 1 – Exemples de montages avec boule d'attelage 80



Anhängebock mit Kupplungskugel 80
 Towing frame with coupling ball 80
 Support d'attelage avec boule d'attelage 80



Kupplungskugel 80 mit höhenverstellbarem Innenteil
 Coupling ball 80 with height-adjustable slider
 Parties intérieures réglable en hauteur à boule 80



Höhenverstellbarer Kugelbock
 Height-adjustable ball frame
 Support de la boule réglable en hauteur



Kugelbalken
 Ball drawbar
 Barre de boule



Kupplungskugel 80 mit Flansch
 Coupling ball 80 with flange
 Boule d'attelage 80 avec bride

Bild 2
Figure 2

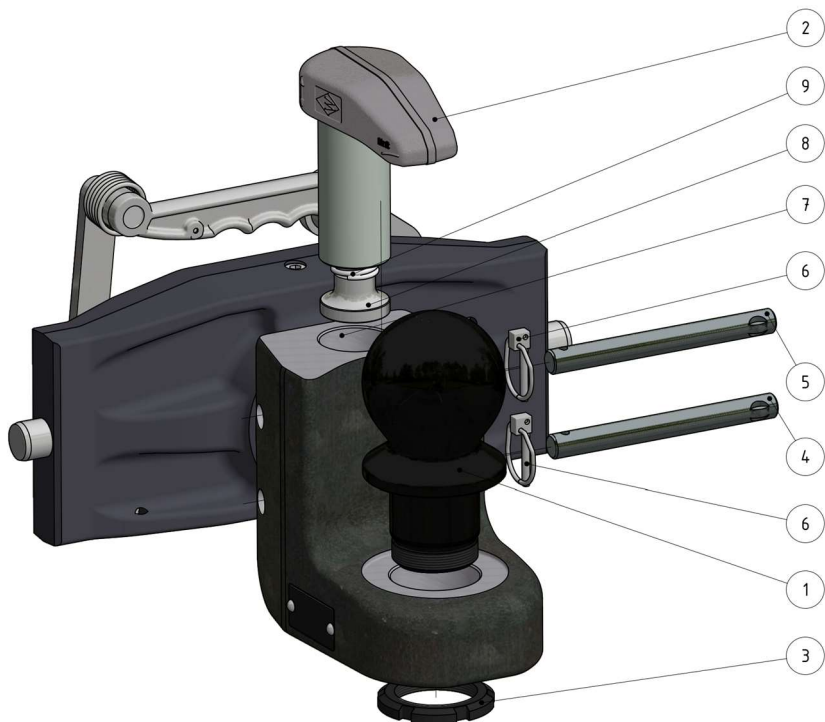

Kupplungskugel 80 mit höhenverstellbarem Innenteil
Coupling ball 80 with height-adjustable slider
Partie intérieure réglable en hauteur à boule 80

Legende:

- 1... Kugel 80
- 2... Niederhalter
- 3... Nutmutter
- 4... Niederhalterbolzen unten
- 5... Niederhalterbolzen oben
- 6... Klapenstecker
- 7... Lagerung
- 8... Stellschraube
- 9... Niederhalter-Feder

Legend:

- 1....ball 80
- 2....retainer
- 3....grooved nut
- 4....locking pin top
- 5....locking pin bottom
- 6....linch pin
- 7....bearing
- 8....set screw
- 9....retainer spring

Légende:

- 1....boule 80
- 2....Dispositif de retenue
- 3....Écrou rainuré
- 4....Goupille de retenue dessous
- 5....Goupille de retenue dessus
- 6....goupille
- 7....logement
- 8....vis de réglage
- 9....ressorts de retenue

Bild 3
Figure 3

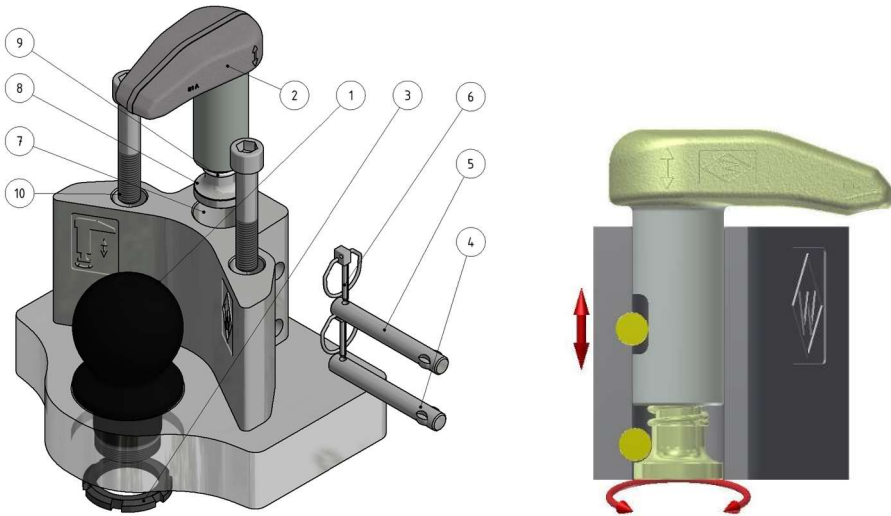

Einstellbarer Niederhalter
Adjustable retainer
Dispositif de retenue réglable

Bild 4
Figure 4

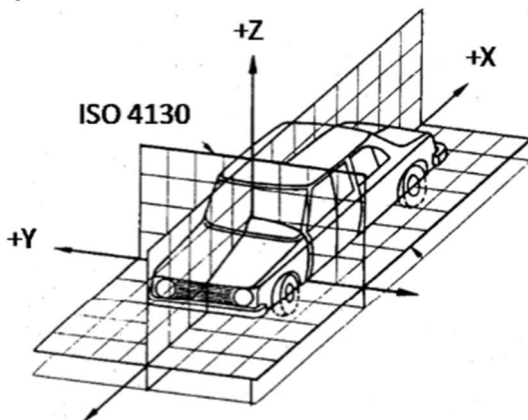

Bild 5
Figure 5

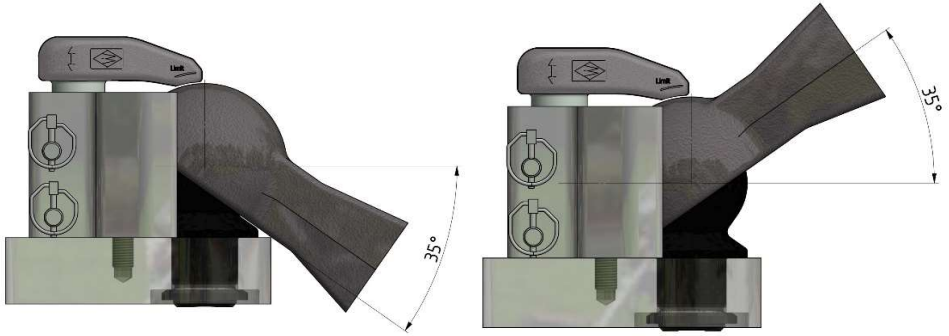

Schwenkwinkel um Y-Achse (Querachse)
Pivot angle around Y axis (transverse axis)
Angle autour de l'axe Y (axe transversal)